

MOBILITY manager

Magazine for Public Transport



Keolis SA gradually converts to electric drive with PSIEbus in the depot near Paris-Vélizy

From Vélizy to Versailles via eBus

Product Report

Automatic Train Operation
Foundation for Climate-
friendly Rail Transport

Product Report

E-Mobility in public transport
Advantages Through
Optimization and Open
Interfaces

Product Report

Baselland Transport AG relies
on electronic roster
More Than Just Corona
Protection

EDITORIAL

Dear Readers,

as we all know, unusual situations sometimes require us to tread new paths. 2020 was a year that forced us to break new ground and reorganize our working environment.

The continuation of projects, the maintenance of existing customer relationships and the development of new ones have always been our top priority. We can proudly say that we succeeded in doing so, that we overcame many challenges, and that we can draw many positive conclusions from this for our future work.

For example, the introduction of PSlebus, our depot and charging management system, took place completely remotely for the first time – at French company Keolis in the Paris Vélizy depot. Read more on this in our cover story.

The conversion of bus fleets to electric drive is in full swing, as evidenced by new orders from BVG Berlin, Verkehrsbetriebe Hamburg-Holstein, Stadtwerke München or currently



from Verkehrsbetriebe Zürich. We are supplying Luxembourg-based bus company Voyages Emile Weber with the Moveo personnel dispatching system in addition to PSlebus. We are very grateful for the trust you, dear customers, have placed in us.

We are therefore particularly pleased to welcome you to our in-person user conference taking place in Berlin in September. Rest assured that we have once again put together a varied conference program, this of course with the required safety measures. We have allowed a generous length of

time for the interaction between the participants. After all, we have only seen each other via screen for many months. This year, we will hold the event in conjunction with Moveo for the first time, thereby enabling you to gain an insight into the latest developments in personnel dispatch.

Last but not least, we are celebrating a double anniversary this year. Moveo turns 30, while PSI Transcom turns 40. Together, we look back on many successful years of software development in public transport and we look forward to continuing our success story with you.

In this new issue of MOBILITY manager, we talk about what else is new from the projects and in product development.

I hope you enjoy reading it!

Torsten Vogel
General Manager
PSI Transcom GmbH

CONTENTS

TITLE STORY

From Vélizy to Versailles via eBus..... 3

PRODUCT REPORTS

ATO: Foundation for Climate-friendly Rail Transport .. 6
Advantages Through Optimization and Interfaces..... 8
Digital Vehicle Data – Gold of the 21st Century..... 10
Making the Best Decision with Multi-criteria Planning 12
Training Can be Planned 15
Swapping Services with Success..... 18
BLT: More Than Just Covid Protection..... 19

INTERVIEW

30 Years Moveo: Three Questions to Alvar Schulze 17

NEWS

New Customers in Germany, Luxemburg, Switzerland . 21
40 Years PSI Transcom..... 23

EVENTS

User Meeting, ITS Congress 22



Keolis SA gradually converts to electric drive with PSIEbus depot near Paris-Vélizy

From Vélizy to Versailles via eBus

Anyone who takes the bus from Vélizy to Versailles today is very likely sitting on an eBus. Keolis, the bus operator responsible, owns a total of 86 vehicles at its Vélizy depot. Of these, 50 are now electrically powered. The PSIEbus depot and charging management system ensures that the vehicles are reliably dispatched and safely charged. This was introduced remotely, headed up by Keolis SA, due to the covid pandemic.

In France, too, more and more electric buses are on the road – especially in the Île-de-France region, comprising Paris as well as seven surrounding counties. The transport authority responsible, Île-de-France Mobilité, wants to have around 5,000 large buses in and around Paris running emission-free and quietly by 2025. In this context, it also gave Vélizy bus depot operator Keolis SA the green light to gradually convert to an e-fleet. The fleet now comprises 50 elec-

tric buses, operated in parallel with the 36 diesel buses. On the IT side, it all revolves around the PSIEbus depot and charging management system from PSI Transcom. This system combines the PSIEdms depot management module with the PSIsmart-charging system for charging management.

In addition to the Berlin-based software provider for public transport solutions, two French companies prevailed in the Europe-wide tender: Manufacturer IES Synergy won the

supply of the 50 chargers, while construction company Spie batignolles énergie secured the transformers and implementation of all construction measures.

Remote PSIEbus launch

Before the e-buses could depart from the Vélizy depot, a few hurdles had to be overcome. First of all, the general strikes in France at the end of April 2019 made life difficult for the project team. On top of that, from March 2020 onwards, the covid pandemic presented a very unique challenge. During the first lockdown in France, not only did construction work in the depot have to be interrupted, but the production and delivery of the e-buses and chargers were also delayed. In addition, since business trips both within the country and

between Germany and France were difficult or impossible for long periods of time, it was decided that the depot and charging management system would be implemented remotely. Gradually, everyone involved became more comfortable with this form of collaboration, which is certainly suitable for projects and collaborations such as these, which extend across national borders, with or without the pandemic.

Diesel and e-buses reliably dispatched

PSIeibus ensures optimal dispatching and on-demand charging of incoming electric buses. In France, all buses are required to display route plans on paper. As a result, each vehicle is assigned to a maximum of two routes. Using OKAPI vehicle deployment planning, the dispatchers assign the vehicles to the respective daily routes a day in advance. This planning is transmitted via an interface to PSIeibus, where it is linked to the timetable data from the HASTUS timetable system. PSIeibus thus determines the



Parking of the electric buses at the Vélizy depot.

individual vehicles' actual charging demands. However, PSIeibus takes account of not only the respective block when determining the charging demand and the associated ranges. The prognosis also includes the weather forecast and thus weather conditions, which can also influence the vehicle ranges.

When a bus enters the depot, the connected positioning system identifies which vehicle it is and conveys this information. While diesel

buses are assigned to a fixed parking space, e-buses are assigned to a charging column depending on their state of charge (SoC) and next route. The depot offers 32 chargers with a charging capacity of 50 kW and 18 chargers with a charging capacity of 100 kW. Each one of them charges with the maximum energy available. PSIeibus has to take several factors into account in the process: For example, when the e-buses arrive, the system can only estimate the remain-

ing range. Only when a vehicle is connected to a charging column does the system receive information on its actual state of charge. In addition, the battery management system negotiates the charging power with the charging column individually, depending on the state of the battery. If a battery is too hot, for example, it will only admit charging at significantly lower kilowatts.



Due to the Corona pandemic, PSIeibus was introduced remotely.

The system therefore continuously monitors the charging process and compares it with route scheduling. If the target state of charge cannot be reached in time, it generates one alarm an hour before and another one ten minutes before the scheduled departure time. The dispatcher can then swap vehicles if necessary.

Integrated charging management

The PSISmartcharging integrated charging management system also continuously monitors the electrical charging infrastructure at the depot and controls the charging processes, taking account of the limit values of the electrical equipment and the operational requirements. The PSIEEMS module transmits these in the form of priority lists. This is where, by combining knowledge of the processes in public transport with those in energy supply, the holistic approach of PSIEbus pays off. For example, the grid connection capacity in Vélizy was initially expanded to 3000 kVA in preparation for charging the electric buses. The same applies to the supply network: A medium-voltage network in ring formation supplies three new transformer stations next to the exist-

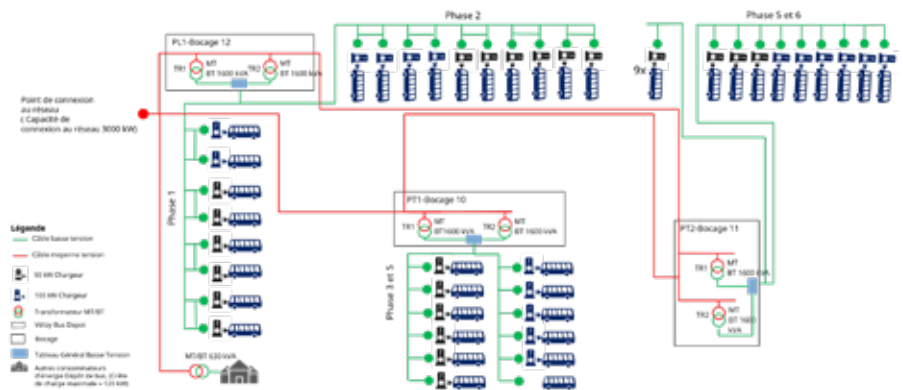

Electrical supply at the Vélizy depot.

ing administration building, each of which is equipped with two 1600 kVA transformers. The total of 50 chargers are fed via these three stations. The PSISmartcharging system, which is compliant for KRITIS infrastructures, records the necessary and existing data points such as switch positions and measured values. If the system detects an impending bottleneck at a transformer or on a line, the load management system intervenes: It either adjusts one enabled charging process downwards or postpones another.

Security of supply even in the event of a fault

In addition, it also ensures security of supply in the event of a communication fault: As soon as the chargers connect to the system, it receives

default charging profiles. These are provided with a fallback value that is determined in such a way that all chargers release power which can be used to charge the buses in the event of a fault. Last but not least, the module continuously visualizes the status of the individual chargers and transmits the representations to the Depot Management System. In this way, the dispatcher is alerted to failures and errors in real time and can respond in a timely and appropriate manner.

Emission-free on the road

Quiet and emission-free bus transportation is a goal which the Île-de-France region is moving ever closer to achieving. This is being helped along by the transition of the Vélizy depot to the parallel operation of 50 new e-buses and some remaining diesel buses. By choosing PSIEbus, the integrated depot and charging management system, Keolis has opted for a holistic solution that will enable the safe and reliable operation of electric urban transport in the future. ☺

Keolis SA

- French Public Transport Company (Keolis Group), subsidiary of the French national railroad (SNCF)
- Headquarters: Paris
- 65 000 employees worldwide
- Operates a public transport network of some 364 km of metro lines, 985 km of streetcar lines and 7000 km of railroad lines, as well as 21 650 buses, on behalf of 300 transport authorities
- Carries more than three billion passengers per year

PSI Transcom GmbH

Jost Geweke
Business Development Manager
jgeweke@psi.de
www.psitranscom.com

Product Report: Automatic Train Operation (ATO)

Foundation for Climate-friendly Rail Transport

Autonomous rail transport is already a reality in the major European cities. In Germany too, it is gaining momentum as an important piece in the puzzle of modern mobility concepts. What we are starting to see here: When it comes to central dispatch interfaces, modular and agile control systems are particularly suitable.

S-Bahn Hamburg is currently taking the next step toward sustainable public transportation through the “Hamburg Digital S-Bahn” pilot project. Four regional trains will be running in a highly automated manner between the city’s Berliner Tor and Bergedorf/Aumühle stations by the end of the year. The drivers of these trains will only intervene in the event of irregularities or faults. If the project is successful, the entire regional train network will be incrementally digitized. S-Bahn Hamburg is doing this using its PSItraffic Train Management System. This solution from PSI Transcom has been monitoring and controlling Hamburg’s regional rail traffic and reliably providing passengers with train connection updates for over 20 years now. As part of the ATO (Automatic Train Operation) equipment, the system transmits the timetable and train stop information to the ATO system. In the future, this information will be transmitted via radio to the on-board ATO system in the form of journey and segment profiles – including the stopping locations – depending on the tensile strength available. This information thereby forms the foundation for highly and fully automated train operation.



In Hamburg, passengers will soon benefit from higher train frequencies and more punctuality.

Why are more and more transportation companies opting for ATO? The reason is obvious: Because the mobility of the future must be sustainable, demand-driven and reliable. Autonomous driving plays a key role here. It means that all processes operate automatically or semi-automatically de-

pending on the degree of automation: Driving and stopping, opening and closing the doors, or stopping immediately in the event of a fault.

ATO provides answers

A key impetus behind this development is the environmental aspect. Smoother acceleration, driving and

braking make these trains significantly more resource-efficient and thus more climate-friendly in transit. ATO in the city can also provide the answer to the growing demand for capacity and availability: It allows train frequencies to be increased in line with demand while maintaining a high level of safety and requiring only minor structural changes to the lines. Some major European cities already have autonomous metro trains running at intervals of just 90 seconds based on Communication-Based Train Control (CBTC) systems. Passengers there benefit from not only the higher train frequency, but also the improved schedule stability and punctuality. Demand-responsiveness is another advantage that the high flexibility of ATO brings.

ATO in urban traffic

An ATO system essentially consists of the control system and the ATO components, which can be trackside

as well as on-board. While the former are responsible for trackside communication, the latter collect static and dynamic route and schedule data from the Traffic Management System and transmit it to the ATO on-board devices.

These onboard components calculate the optimal driving

profile and control the accelerators and brakes.

Thanks to automated control and safety systems, rail traffic already operates with a high degree of automation today, which provides a basis for further development towards ATO. This is partly due to the stable environment. However, this is precisely the point where significant differences can be identified within rail transport. Light rail systems, for example, are based on a completely closed network of lines and are exposed to significantly fewer external risks due to the tunnel system. No level crossings or interfaces with other lines exist, and storm damage does not occur. Safety on the platform can also be reliably ensured by automatically retractable walls, as has already been demonstrated in practice. Higher speeds, dependencies on other rail lines and stronger external influencing factors such as the weather have to be taken into account in long-distance traffic. Another challenge is the lack of standards and numerous proprietary interfaces. There is also a lack of uniform system boundaries as a result.



PSItraffic considers the entire route network and takes over the scheduling control.

ment and optimized route and personnel scheduling through train control and passenger information. The advantage compared to simple train scheduling: The system considers the entire route network and takes on the dispatch management. Faults or conflicts can thus be identified early, and dispatchers re-

ceive optimized suggestions for how to deal with issues in real time. Dispatch decisions are communicated to other systems at the push of a button. In conjunction with ATO operation, highly repetitive work is eliminated and the optimal capacity utilization of available resources is enabled.

In short: Interlocking technology, which has grown over the decades and is often heterogeneous, requires a future-oriented and flexible control system with variable interfaces for connection to a central control center solution. In contrast, ATO or CBTC solutions, as a basic evolution of a train control system, are not very suitable for the fully automatic control of entire networks via schedule dispatch and including the integration of neighboring systems. In addition, a generalist system requires larger investments in infrastructure and interlocking technology. 🌀

Adaptable to requirements

So are generalist control systems equally well suited as a central data hub to long-distance and freight traffic as well as to less complex, autonomous urban traffic? Especially in an urban context, more agile systems that can be adapted as needed prove their worth, as hands-on experience (see Hamburg S-Bahn) shows. They allow loose system boundaries to be individually adapted.

Therefore, software solutions such as PSItraffic, which are fully integrated into different system landscapes via open, standardized interfaces, are also suitable in an ATO system as a central dispatch interface to control rail operations. In particular, communication between the control system and the vehicle-side ATO onboard unit (OBU) via standardized interfaces such as subset 131 and 126 enables optimum flexibility in the selection of the vehicle supplier or the retrofitted OBUs. The modular design is crucial. It means that the system can be expanded in different ways to combine the essential systems in rail operations – from short-term schedule dispatch, precise workshop manage-

PSI Transcom GmbH

Robert Baumeister
Division Manager ITCS/TMS
rbaumeister@psi.de
www.psitranscom.com

Product Report: E-Mobility in public transport

Advantages Through Optimization and Open Interfaces

As public transport converts from diesel to electric vehicles, integrated software systems that combine depot management and the charging system have proven particularly effective. Two issues are especially significant here: Optimizing the interaction between driving operation and charging management on the one hand, and creating standard interfaces between various systems on the other hand.

The public transport sector has taken on a pioneering role in the conversion to alternative drives. The EU's Clean Vehicles Directive and its mandatory minimum quotas for the procurement of zero-emission vehicles are providing strong impetus in this process. Companies are therefore coming under increasing pressure to develop a practicable and future-proof electrification strategy. The challenge: Only a few companies and suppliers have an overall understanding of the requirements of a public transport operation and the management of an electrical infrastructure. However, this is precisely what will be crucial in order to create the necessary structures quickly and use them efficiently in the long term while remaining independent of individual manufacturers' technologies. For example, the interaction between driving operations and charging management will need to be optimized

and standards for communication between the various systems created.

Various influencing parameters

So how can we ensure that buses are available on time and fully charged as needed – and do so as economically as possible? The influencing factors and dependencies involved extend far beyond the limited battery range, for example. Each individual vehicle's range is also influenced by the age of the battery, the outside temperature or a bus driver's specific driving style. The charging infrastructure, the specific connected load and possible restrictions on the electrical supply due to grid fluctuations also exert a significant influence on vehicle charging. Last but not least, aspects such as grid-compatible charging, battery conservation or charging at favorable conditions can become a relevant economic factor. Ultimately: Managing a driving operation powered by elec-

tricity requires a much more planned approach than other driving operations did in the past. A large number of operational and electrical influencing parameters and their interdependencies need to be taken into account and optimally balanced. This can now be done using software alone.

Optimizing dependencies

In this regard, companies benefit from integrated depot and charging management systems designed specifically for zero-emission public transport. By combining the PSIEdMS depot management module with the PSISmartcharging integrated charging management system, the PSIEbus system amalgamates operational pre-planning and electrical systems data. This means that vehicle and operational data is merged with weather forecast data as well as information on the feed-in points, transformers and chargers. This forms the basis for resource-conserving, demand-based charging processes. At the same time, in the event of imminent overload or restrictions in the energy supply, power is redistributed automatically, stabilizing the network status while still ensuring reliable operation.



In the event of imminent overload or restrictions in energy supply, power is automatically redistributed to stabilize the grid.

To determine the charging strategy for each vehicle, the system avails of its integrated, PSI proprietary Qualicision optimization software. This enables all relevant criteria and their complex, sometimes even contradictory, dependencies to be balanced at high speed. In doing so, companies can individually prioritize, weight and flexibly adjust and display all parameters. The following scenario is conceivable, for example: The minimum state of charge of a battery for the next scheduled route is incorporated into the overall planning as a requirement to be met, i.e. a restriction. In parallel, qualitative criteria such as a battery-friendly reduced maximum charging power or a decreased target state of charge of the battery, which contribute to slowing down battery aging, are prioritized in relation to each other, weighted and also incorporated into the charging planning as criteria.

Standardized communication

In the future, connected systems such as DMS or ITCS will need to be closely interwoven with charging and load management systems, and these in turn with chargers. As a result, interfaces need to be converted into standards. Only processes and responsibilities defined and standardized in this way will be able to ensure investment security and allow transport companies to freely select their suppliers.

The recently published VDV 463 interface originates from the Hamburg Hochbahn project. This standard describes the bilateral exchange of information between the depot and charging management system and defines its data format and transport protocol. This includes, for exam-



At Hamburger Hochbahn AG, the VDV 463 interface was developed in a pilot project.

ple, which operational parameters are transmitted from the Depot Management System (DMS) to the Charging Management System (CMS) via the charging request and how, where and at what priority level, and how the CMS sends back the charging planning in detail as charging information.

Interfaces between charging management and chargers

The open and certified OCPP 1.6 interface (Open Charge Point Protocol) already exists for the connection between the CMS and chargers. It describes, on the one hand, how the messages between the two components are used for monitoring and charging control and, on the other hand, the expected behavior of the charging infrastructure and the buses, including the linked data. The problem: The way in which messages are used in context remains open. For example, the protocol does not specify in sufficient detail which charging profiles must be used for central charging control or which data the charging

stations need to provide to enable central monitoring and charging control. The same applies to the description of use of the charging profiles in the event of communication failures or faults to the power supply. However, this clear definition of use of the smart charging profiles is exactly what is needed for the reliable charging and distribution of the electric buses in the depots.

Consequently, the different or incomplete implementation of the smart charging profiles causes high costs when connecting the chargers to a load and charging management system. Therefore, PSI has specified the messages of OCPP 1.6 in the “PSIready” document. This includes, above all, the consideration of restrictions to the energy supply as well as the precise definition of an emergency operation, which is absent from most interface descriptions. 🌀

PSI Software AG
Martin Frenzel
Manager Development and Projects
mafrenzel@psi.de
www.psienergy.de/en

Product Report: The limits of standardization

Digital Vehicle Data – The Gold of the 21st Century

“Data is the gold of the 21st century” – this phrase is now on everyone’s lips. But is it really the data itself that is valuable? Today, big data analysis is to data, as shovels were to the gold rushes of centuries past. The “digital shovels” of today are used to dig for hidden data treasures so that valuable information can be extracted. Through this process, “big data” becomes “smart data.” Not the raw data itself is the new gold, but rather the information and insights that can be drawn from it.

Public transport rail vehicles and buses generate many different types of data. These include sensor data and parameters from the vehicle control system, location and punctuality data from ITCS and passenger information systems, as well as data from driver assistance and monitoring systems.

Most digital data treasures still lie unused in the vehicle, hidden in the memory chips of countless sensors and system components. And even after being collected and stored in databases, the important information is often embedded in a confusing mass of redundant data.

Panning for gold: Intelligently filtering and analyzing data

Turning raw data into information that can be evaluated usually requires prefiltering as a first step. This filtering process depends heavily on the respective application and can evolve over time in response to changing requirements.

Various tools and methods are used to extract the desired information from the prefiltered raw data (e.g., time series analysis, data mining, business analytics), which is then further processed in downstream back-office systems. As business processes are digi-



Today, valuable raw data is obtained with digital shovels.

tized, intelligent data analysis delivers higher quality, transparency, and security. Paper can largely be eliminated.

The challenge of a standardized system architecture and interfaces

A standardized system architecture and interfaces is required to ensure that raw data is collected and processed in a compatible manner across manufacturers and users.

In addition to the widely-used CAN (Controller Area Network)-bus, there can also be any number of additional fieldbuses, for example Profibus, WorldFIP and Bitbus.

Here, the trend is moving toward replacing these with Industrial Ethernet

and IP-based communication, except for time and safety-critical control tasks.

In 2002, seven European commercial vehicle manufacturers launched the FMS (Fleet Management Interface) standard, which makes specific vehicle data accessible to third party sup-

pliers. However, only a small percentage of all telematics data present in the vehicle is available via FMS.

Reading additional data from the internal fieldbuses is largely prevented by the vehicle manufacturers.

For rail vehicles, the challenges are even greater. Although standardized fieldbuses exist, e.g., Multifunction Vehicle Bus (MVB) or Wire Train Bus (WTB), the messages and error codes transmitted are manufacturer and device specific.

This makes ongoing collaboration with vehicle manufacturers all the more important in pushing forward standardization activities and expanding the data specifications in which users have a legitimate interest.

New requirements

The FMS standard is geared toward vehicles with internal combustion engines. In the age of electromobility, the vehicle data required is changing, for example, to enable charge management for electric buses.

In addition to the well-known State-of-Charge (SoC), there are many other important parameters, for example the State of Health (SoH), the charge throughput, and the battery cell voltage and temperature.

These values are crucial for intelligent charge management, which optimizes charging times while also considering battery life.

Data hub for vehicle data – Vehicle Data Center

To make the information contained in the raw data usable, PSI Transcom GmbH is developing the Vehicle Data Center (VDC) as a structured data platform for vehicle data.

The first step is to acquire the existing raw data from the vehicle, to filter it and to store it in a well-defined form. The interface of the VDC for data acquisition is either a telematics box installed in the vehicle, which “listens” to the data traffic on the fieldbuses or directly acquires sensor data, or a connection to the IT backbone of the system supplier or vehicle manufac-

Thanks to their many years of experience with AI-based software, tools like the Deep Qualicision Tools from PSI are an excellent solution.

The processed data (smart data) is either forwarded to system overviews (dashboards) or to downstream systems (e.g. depot and workshop management) for further processing.

Enabling cross-user applications

VDC is able to merge different data sources and evaluate them together. When storing raw data, the data owner can assign usage and access rights.

Not only is data protection and security ensured, but cross-user analyses are also made possible.

For example, multiple transport companies may operate the same type of vehicle under similar conditions. They grant each other permission to jointly use the collected data. Now, analyses can be performed based on a cross-user data set, thereby improving the prediction of future events, e.g., for predictive maintenance.

As part of a research project, the interfaces and architecture of the VDC will be standardized and developed in close cooperation with vehicle manufacturers, potential users and the ITxPT association.

The Vehicle Data Center thus becomes the central tool for mining valuable gold nuggets from raw data.

The main beneficiaries will be users such as transport companies and associations, who will benefit from cross-manufacturer solutions. 

PSI Transcom GmbH
Michael Preusker
Innovation Manager
mpreusker@psi.de
www.psitranscom.com

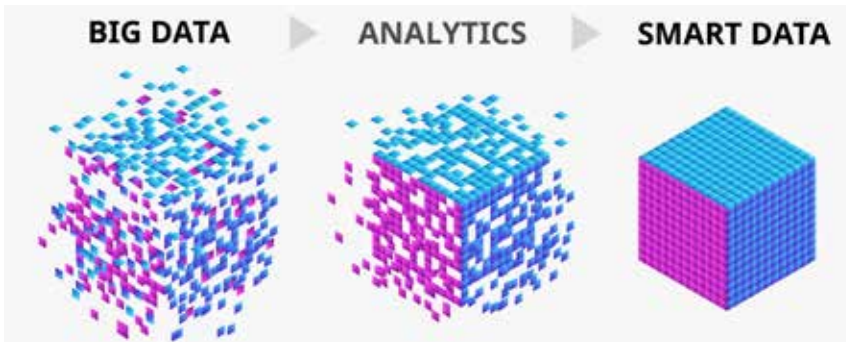

Intelligent filtering and analysis turns big data into smart data.

New standardization approach

The nonprofit association Information Technology for Public Transport (ITxPT), which PSI Transcom recently joined, has set itself the goal of promoting the standardization of IT applications for public transport. ITxPT consistently pursues a data-focused approach, independent of the vehicle hardware.

The TiGR protocol (Telediagnostic for Intelligent Garage in Real-time) has laid a foundation for standardization in the area of vehicle and diagnostic data. But there is still a need to extend this, for example to include electromobility.

turer, which has already transferred this data to its background system using its own OEM solutions. VDC supports both variants.

A filter which extracts the desired raw data in the required granularity from the available data stream is usually necessary for data acquisition. Ideally, it can be configured online or remotely to enable a flexible reaction to different data requirements at runtime.

The filtered raw data is first stored in the “big data area” of the VDC. Various tools can be used to invoke different data analysis methods, for example qualitative labeling and KPI analysis.

Product Report: Harmonized depot and workshop management

Making the Best Decision with Multi-criteria Planning

Reliability, quality, efficiency and sustainability are pivotal challenges facing public transport companies. Consequently, companies that link all the related processes in an optimized way have an advantage. The coordination of operations and workshops holds great potential and stands to benefit all involved.

Ensuring daily operations, meeting passengers' increasing quality demands, and reducing costs: The challenges facing transportation companies are many and varied and almost impossible to meet without the support of information technology. The integrated interaction of the various departments and IT systems is more crucial now than ever before. This is the only way to leverage all areas of potential. Depot Management Systems (DMS) play a key role here. They monitor and control all processes in a depot, from vehicle ar-

rival and supply through repair and storage. For example, a DMS can be used to order and block vehicles for workshop tasks and to classify the vehicles' operational capability at the same time. To date, however, selecting vehicles to be sent to the workshop has usually been carried out solely via the data-carrying (master data) systems such as those from SAP, Microsoft Dynamics NAV or Maximo, which follow standardized rule-based maintenance or cleaning intervals. These systems do not know or take the on-site operational situation into account when planning.

Even special workshop resources that may be relevant to a job are not included in the selection process. This is further complicated by the fact that detailed planning of work processes in the workshop itself is frequently done manually using analog planning tables.

In simple terms, this means: Workshop activities and operational requirements are characterized by numerous media discontinuities and lack coordination. The consequence: Vehicle bottlenecks are more likely and the utilization of workstations and employee capacities in the workshop is uneven. A look at practice shows that vehicles which cannot be processed due to a lack of resources are nevertheless reserved for processing by the workshop on a daily basis. This means that vehicles are unavail-

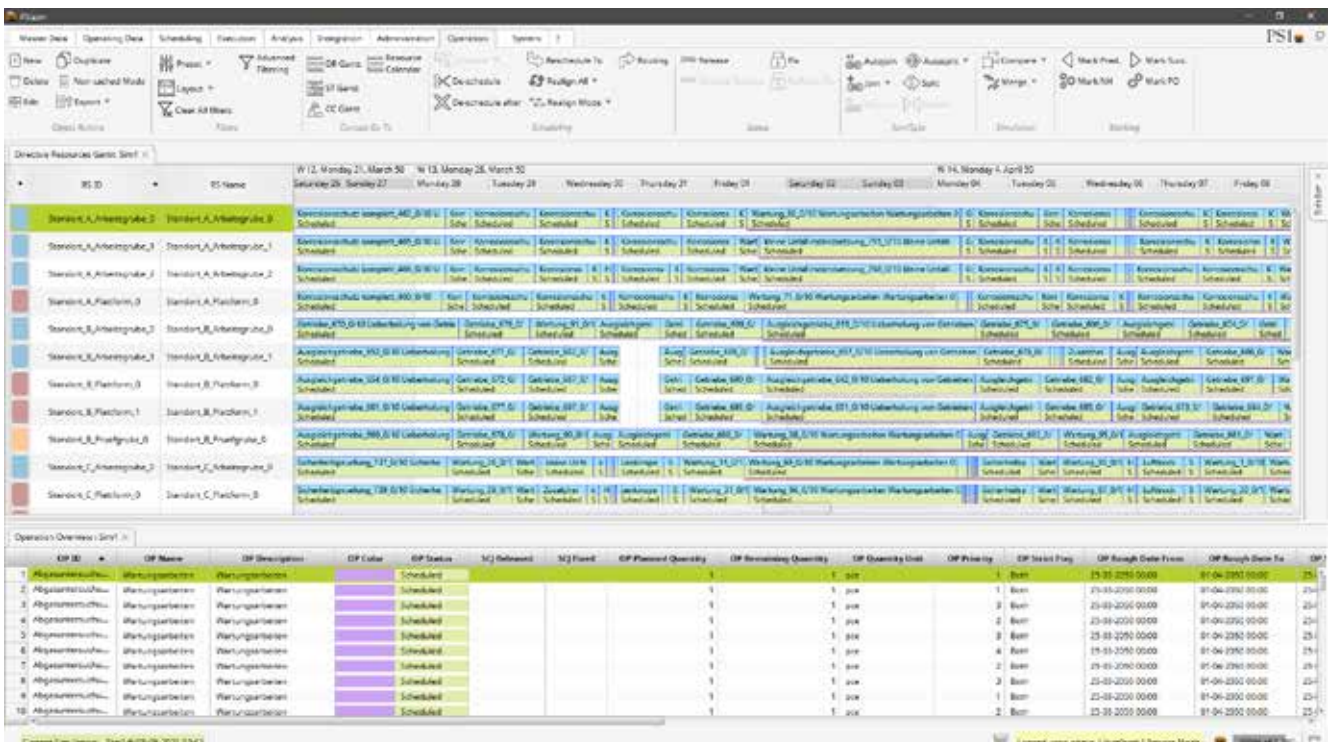

Scheduled workshop orders in the Gantt chart.



Operational workshop management – optimal capacity utilization, more room to maneuver, reliable driving.

able for dispatch (damaged in some way that prevents their use) on a regular basis, causing bottlenecks for no reason.

Operational business has priority

Therefore, considerable potential can be leveraged by automating and harmonizing these processes. A system that is also aware of the operational situation in the depot should be introduced to take over the planning of workshop orders. In this context, it makes sense to expand the Depot Management System used, which builds a bridge between the workshop, operations and the systems used in each case. Solutions that monitor the current operational situation in real time and reliably provide vehicles for scheduled workshop appointments using optimizations have an advantage. In addition to interfaces for importing and ex-

porting workshop orders, planning resources and fault information, a corresponding add-on module should also include a graphic planning table that provides an overview of the current occupancy of the workstations in the workshop and utilization of employee capacities. For instance, if a vehicle is needed for operational purposes, the DMS can overwrite the leading system's workshop order and postpone it so that the timing suits. In parallel, it can reserve another vehicle for the workshop based on the known, operational requirements and thereby ensure utilization of the workstations and employee capacities. This enables the extended workshop management to take account of the numerous unplanned orders that come in throughout the day and allows for continuous readjustment of the solution calculated statically in the morning.

Automatic job planning ensures optimum capacity utilization

The Qualicision optimization module, which is part of PSITraffic/DMS, facilitates the optimized automatic scheduling of orders, taking various – even conflicting – parameters into account. This allows criteria to be assigned different priority levels during vehicle selection. Ensuring operational running is always top priority. As such, this criterion is to be regarded as a restriction: If a vehicle is in high demand in operations due to operational circumstances and the earmarked deadline has not yet been exceeded, it cannot be set aside for the workshop. In contrast, criteria such as compliance with specified maintenance, inspection and cleaning intervals, as well as the requirement to utilize the workshop's capacity evenly are assigned different priority levels in the decision-making process. These criteria may be de-

fined individually, depending on the availability of resources, especially those such as work statuses, personnel or tools.

Finally, the process of finding solutions is completely automatic and the module only generates reports if conflicts which cannot be resolved automatically arise. These conflicts are automatically postponed to the future to allow the employees in charge to search for solutions and respond in a non-pressurized manner.

Thus, the previous planning of work steps manually using an analog

Integrated workshop management ensures driving operations

By integrating operational workshop management into the DMS, vehicles and required work can be consistently tracked within one system. This eliminates the need for paper documents and manual data transfers to a second system. More precise planning and short response times prevent vehicle shortages, which in turn ensures that the driving operations run smoothly.

The use of intelligent decision-making software, such as that in the PSITraffic

workshop management systems, for example those for commercial processing, can be maintained.

More room for maneuver

Linking operations and the workshop via an operational workshop management module opens up considerable efficiency potential. A particularly valuable aspect is the integration of a multi-criterion decision-making aid that allows companies to individually prioritize and weight the planning parameters that are relevant to them. This solution,



Unplanned orders are flexibly taken into account throughout the day. The solution statically calculated is continuously readjusted.

planning table in the workshop can be replaced by a digital Gantt display. It provides an overview of work status occupancy as well as the utilization of employee work capacities. Work orders can also be manually assigned to days in table format and via suitable dialog boxes, as well as in combination with existing assignments.

Depot Management System, also allows for the balancing of conflicting goals and the calculation of balanced results. The simultaneous transition from manual work scheduling to an automated system in the workshop also helps optimize the utilization of individual work statuses and employee capacities.

Additionally, connections to existing

which is currently unique on the market, provides transport companies with investment security for existing IT systems in the workshop. ☺

PSI Transcom GmbH

Sven Jürgens

Division Manager Depot Management

[sjurgens@psi.de](mailto:sjuergens@psi.de)

www.psitranscom.com

Product Report: Data-based Profahr training management

Training Can be Planned

Based on the large amount of data collected in companies, well-founded decisions can be made in advance. This also enables plant managers in driving operations or HR managers for driving services to leverage valuable potential. For example, in training management.

MOVED



Transparent education management makes it possible to plan ahead and monitor the impact of measures.

Digitalization and automation are changing the world of work rapidly. Besides HR departments, flanking areas such as personnel dispatch are also required to monitor this development in transportation companies. Studies show that executives expect much greater emphasis on a range of topics including employee qualification and competence and talent management in the area of human resources management. The intelligent use of data in these areas

promises a significant improvement in HR decisions and insights and is becoming a real success factor in times when skilled workers are scarce. The surmounting of heightened limitations, as well as the use of digital tools, is considered the key to success. Digital tools provide the basis for the processing of the (new) tasks in a flexible and speedy manner using reliable data, e.g. in the field of mandatory training, strategic further training or internal recruitment measures.

Planning and budgeting for training courses in advance

To this end, the Profahr personnel dispatching system can be expanded to include the training management module, which is made up of four interrelated modules: 1) events, 2) deadlines, 3) tasks, 4) controlling. Operations or HR managers for the driving service can use this to free up members of the superordinate personnel department and assign them specialist personnel topics. This may include, for example, managing reg-

ularly occurring EU Professional Driver training courses in a proactive manner. In this case, the module not only automatically reminds the individual drivers of the deadlines they have set.

The course dates can also be strategically planned and adjusted in line with rosters. If the planning results in additional tasks, these can also be saved and processed in the system. When a training certificate is printed, the system updates itself automatically and creates all the necessary training modules, deadlines and reminders again.

HR managers may also precisely calculate the necessary budgets for the various initial and further training courses and carry out long-term planning for the years to come using the training management system. Last but not least, the option whereby dispatchers can themselves save and

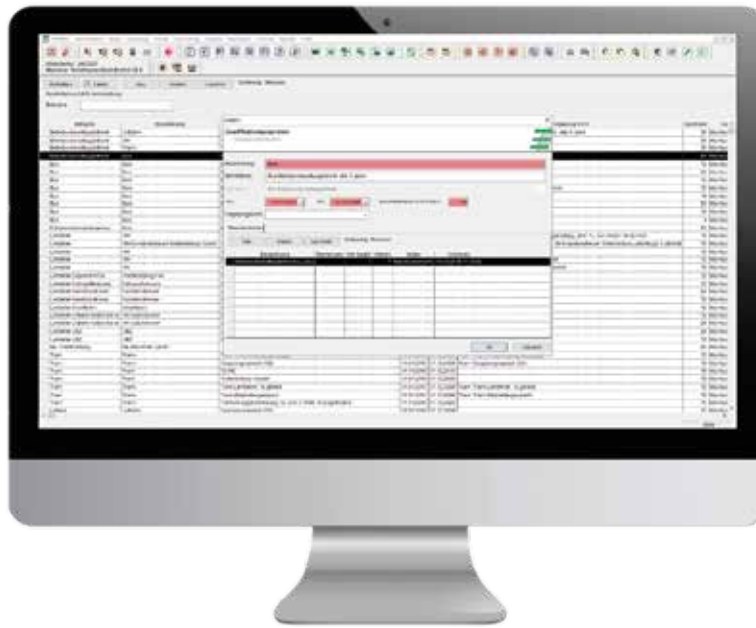

Plan and document training courses and keep an eye on budgets with Profahr Education Management.

then monitor specific documents or notes, such as evaluations of meetings with employees or the documentation of red light violations and other fines, has proven itself in practice. By providing this information directly at the point of occurrence in the future, the time-consuming compilation of documents on these processes can be eliminated. Varying levels of information are provided depending on the extent to which the respective individual is involved

in the underlying work processes. In addition, the amount of manual work required to prepare and conduct training courses, which can be significant, is drastically minimized.

More scope

Transparent education management provides data that enables challenges to be recognized at an early stage and problem areas identified as well as the effect of measures to be observed. Thus, Pro-

fahr education management also gives specialist HR managers more scope. This means personnel and deployment planners, for example, can make more precise decisions and can rest assured that enough qualified staff members are available at all times. ☺

Moveo Software GmbH
Peter Rosenheinrich
Head of Sales
peter.rosenheinrich@moveo-software.com
www.moveo-software.com



Interview: 30 Successful years Moveo Software

Three Questions to Alvar Schulze

Moveo celebrated its 30th birthday last year. Due to the lockdown, it did so quietly and without much fanfare. We talked with Alvar Schulze, who manages the company jointly with Matthias Kramp and Torsten Vogel, about the anniversary, the past and the future.

Not every company makes it to its 30th company anniversary. What is the secret to Moveo's long-term success?

The basis was laid by company founders Martin Finker and Matthias Fannrich, who managed and built up the company for 25 years. Besides good ideas, another vital factor is our product, which is subject to continuous ongoing development. This is how long-lasting connections with and trust among our customers have developed. And of course, success doesn't come without reliable employees. Our family atmosphere, in which we discuss and criticize transparently and toast successes together, creates the cohesion that makes continuity possible. Even after the takeover, all the "Moveos" stayed on board – an incredibly high level of trust, for which we are very grateful.

Takeover is a good keyword: Moveo has been part of the PSI Group for three years and works hand in hand with PSI Transcom. What are the greatest joint successes and what common vision do you hold?

The order from Voyages Emile Weber in Luxembourg shows how successful our collaboration is and the potential it holds. This is because the close link with PSI Transcom – PSLebus in



Alvar Schulze, General Manager Moveo Software GmbH.

conjunction with our personnel dispatch – was a powerful argument to award us with the contract.

In parallel, we are already working on a software solution for the integrated deployment planning of all resources and their operational dispatch based on the PSI development framework

In addition to our know-how and that of PSI Transcom, this also encompasses the knowledge and technologies of other PSI units.

Back to the anniversary: Unfortunately, the planned celebration had to be canceled due to the pandemic. How upsetting was that for you and your employees and are there any plans to make up for it?

It was a huge disappointment when the planning and organization had to be canceled last March. Especially as it is a tradition at Moveo that the employees and their families travel together for a weekend every five years. For us, there is no question that we will celebrate the 30th company anniversary with our customers and employees – probably next year – “in person and in color”. 🌈



Just in time for the anniversary, the offices were redesigned.

and with the aid of optimization algorithms. The focus is on the responsible use of resources and the support of flexible mobility concepts.

Moveo Software GmbH
Alvar Schulze
General Manager
alvar.schulze@moveo-software.com
www.moveo-software.com

Product Report: Profahr personnel dispatching system with digital swap meet

Swapping Services with Success

The swapping of services between employees is part of the daily work of a personnel dispatcher and is anything but easy. Especially as frustration on the part of the employees has to be avoided. The “swap meet” – an extension module of the Profahr personnel dispatching system – offers a way out.

For those tasked with personnel planning, fulfilling personnel requests for swaps can be a headache: They have to find suitable people to swap with – for a very specific period of time and with the appropriate qualifications. When it comes to driving personnel, driving and rest times also have to be taken into account. As a rule, these are precisely the ones who are difficult to reach to discuss arrangements as they do not have a fixed workplace in the office. Last but not least, common decision-making processes too often lack transparency, which can quickly give employees the impression of arbitrariness and unfair treatment.

Intuitive use – seamless integration

The swap meet for services, which can be integrated into Profahr, allows this dilemma to be solved easily and efficiently. The extension module enables employees to swap services among themselves – intuitively, quickly and transparently. The module does this using all relevant information that is saved in the personnel dispatching system for the employees. This includes,

for example, qualifications, rosters and vacation schedules. The solution is additionally platform-independent, meaning it can be accessed from any device. Smartphones are suitable, as are tablets or company terminals.



Swap meet screens on different devices.

Swap-search-bid

The exchange offers two simple functions: (1) direct swap, which colleagues have already jointly agreed to, and (2) search-bid function, in which employees can post swap requests. In the case of a direct swap, one of the two colleagues enters the day they want to work and the person they want to swap with in the exchange. The system immediately checks for plausibility and potential conflicts. If no violations are detected, the swap proposal can be

saved and forwarded to the swap partner and the dispatcher for approval. The dispatcher then checks whether both parties agree and that there are no other special circumstances that argue against a swap. The module then transfers all the information on the swap to the overarching personnel dispatching system, which adjusts the rosters accordingly. In the aforementioned search-bid function, all the employee does is to enter a service swap request, which can in turn be accepted by a colleague. The subsequent steps correspond to the procedure described for a direct swap.

Beneficial for all involved

Ultimately, a self-determined system that allows employees to swap services among themselves at short notice and location independently leads to a significantly higher level of satisfaction. This also applies to the personnel dispatchers, who are almost completely relieved of a stressful task and have more time for the essentials. At the end of the day, every employer benefits from satisfied employees: Because they are more motivated to work and remain loyal to their companies. ☺

Moveo Software GmbH
Peter Rosenheinrich
Head of Sales
peter.rosenheinrich@moveo-software.com
www.moveo-software.com

Product Report: Baselland Transport AG relies on electronic roster

More Than Just Covid Protection

Making a virtue out of necessity – that is the maxim of numerous companies during the covid crisis. Solutions are being sought everywhere that not only protect people from infection in the current situation, but also offer added value beyond the pandemic. Numerous digital programs, in particular, fall into this category. Baselland Transport AG (BLT), for example, has decided to switch to the mobile roster as part of the Profahr personnel dispatching system in the context of its health protection efforts, and intends to adhere to this solution for its driving services in the future.

Hygienic measures on public transport services affect passengers and drivers alike. For both interest groups,

and in neighboring areas, has also taken up this challenge. In addition to the mandatory wearing of masks throughout the region, for example, a

are also equipped with a glass partition. But it is not just during rides that drivers are exposed to an increased risk of infection. On average 35 of the company's 380 drivers meet in the company's social rooms during shift changes in particular. This used to result in congregations in front of the roster display on a regular basis. The employees would then inquire about vacant services by phone or directly at the dispatch office. "Our employees were often standing close to each other for sev-



BLT Baselland Transport AG carries around 55 million passengers per year by train, bus and streetcar.

public transport companies must create conditions that enable compliance with the applicable hygiene rules in the first place. BLT, the operator of public transport lines in the Swiss canton of Basel-Landschaft

coordinated protection strategy that regulates boarding and alighting via the various doors and the blocking of the front row of seats for passengers is in force on buses. To protect the health of bus drivers, all vehicles

eral minutes – a situation that we had to change quickly as part of the social distancing requirement," describes Andreas Mächler, head of dispatch at BLT.

Seeing vacant services

Together with their software partner, Moveo, those responsible at BLT therefore decided to offer the stationary roster display as a module of their personnel dispatching system as a mobile solution. "We have equipped our drivers with service tablets anyway. They can use these to submit rostering requests, for example, which is another application of the Profahr personnel dispatching system," adds Mächler. Thanks to its experience in dealing with mobile solutions for field staff, BLT is several steps ahead of many transport companies: "We knew of the added value of mobile extensions in principle for all parties involved and how well they are accepted by everyone," Mächler acknowledges. Finally, by allowing drivers to view and sign up for vacant services at any time and anywhere, not only are social distancing requirements being adhered to: "We assume that the driving personnel will now basically look at the vacant services more often and report for suitable rides," de-

scribes Christian Boos, Head of Operations. After all, this avoids extra effort, thereby saving time. At the same time, employees can sign up for services at their own discretion. Last but not least, the dispatchers benefit. They normally have to make countless calls and write e-mails under time pressure in order to staff vacant rides with a suitable employee. More and more, the drivers are actively distributing services themselves, which frees up the dispatchers. "And of course, this applies completely independently of covid," says Boos.



scribes Christian Boos, Head of Operations. After all, this avoids extra effort, thereby saving time. At the same time, employees can sign up for services at their own discretion. Last but not least, the dispatchers benefit. They normally have to make countless calls and write e-mails under time pressure in order to staff vacant rides with a suitable employee. More and more, the drivers are actively distributing services themselves, which frees up the dispatchers. "And of course, this applies completely independently of covid," says Boos.

Mobile solutions convince

Mobile solutions for driving services are an effective means of complying with hygiene and social distancing rules during covid times. However, the changeover from the stationary to the electronic roster illustrates precisely the benefits beyond the crisis: It facilitates the involvement of drivers, who sign up for vacant services of their own thereby relieve the dispatchers. ☺

Moveo Software GmbH
 Peter Rosenheinrich
 Leiter Vertrieb
 peter.rosenheinrich@moveo-software.com
 www.moveo-software.com



The electronic duty roster simplifies the active involvement of the driving personnel and relieves the dispatchers.

News: New customers in Germany, Luxemburg and in Switzerland

Transport Companies Rely on PSItraffic

The electrification of bus fleets and the associated renewal of infrastructure and dispatching systems are in full swing. We are pleased that we have acquired numerous new customers in recent months who place their trust in our PSItraffic/DMS and in the PSLebus depot and charging management system.

which includes deadline monitoring and service swapping modules alongside standard functionalities such as driving and rest time checks, vacation management and data transfer to pay-

PSLebus is set to coordinate and dispatch the vehicles in the Indira-Gandhi-Straße depot of **Berliner Verkehrsbetriebe (BVG)** and ensure that all buses are reliably ready for use at the start of their rides. All depot processes – from vehicle location, parking, supply and workshop, driver registration through vehicle allocation – will be displayed in a digital system. PSIsmartharging, the integrated load and charging management system, checks the depot's overall energy demand and monitors and controls the individual chargers. It was successfully put into operation in a record time of just seven weeks after project commencement.

Verkehrsbetriebe Hamburg-Holstein GmbH (VHH) is also relying on the PSI DMS to digitalize its processes across eleven depots and prepare for the switch to electromobility. The system is connected to the external charging management system via an interface.

PSLebus is to look after vehicle dispatch in two depots of **Stadtwerke München GmbH (SWM)** as well as playing a key role in supporting the company in its goal of offering totally emission-free bus operations by 2030.

Hamburger Hochbahn AG has already been using PSItraffic/DMS to



PSItraffic/DMS will soon be dispatching around 240 buses and 260 streetcars in Zurich.

control the processes at its bus depots since 2014, as well as the electric buses since 2019. Another branch of industry, namely the subway, has now joined the ranks of our customers. In PSItraffic/DMS, an in-house development of HOCHBAHN is replaced by a proven standard solution. The goal is to digitalize the processes of delivering vehicles to the workshops. The order also includes the connection of existing systems. The project is being implemented in an agile development process.

No less than three PSI units are involved in a new project at Luxembourg's largest passenger transport provider **Voyages Emile Weber (VEW)**. Moveo is supplying the Pro-fahr personnel dispatching system,

roll. The depot and charging management system from Transcom and PSI's Electrical Energy business unit will coordinate and dispatch the vehicles at ten depots.

We also have a current order from the **Zurich Transport Authority (VBZ)** which we are proud of. Our DMS is set to monitor and control around 240 buses and 260 streetcars in a total of eight garages and depots here in the future. The system will also automatically support the dispatch of the e-bus charging process, which is set to be more complex in the future. ☺

PSI Transcom GmbH
Susanne Renner
Marketing Manager
srenner@psi.de
www.psitranscom.com

Event: User Meeting PSI Transcom and Moveo



Welcome Back – on September 23/24 2021 in Berlin

No InnoTrans, no IT-Trans, hardly any opportunity for personal interaction – that’s what the last year and a

half has looked like. We are looking to the second half of the year with confidence and are set to organize our

user conference in conjunction with Moveo in Berlin. We cordially invite you and look forward to seeing you again!

As always, a good combination of interesting topics, time for discussions and exchange, and a small social program await.

Our event app provides all important information including lectures and speakers. The access code will be sent out with the registration confirmation.

Of course, the protection and hygiene measures applicable at the time will be observed during the event. 🌿

Register here:



PSI Transcom GmbH
Susanne Renner
Marketing Manager
srenner@psi.de
www.psitranscom.com



The Umweltforum is Berlin’s official Sustainable Event Partner.

Event: ITS World Congress

ITS World Congress: October 11–15 2021, Hamburg

PSI will present intelligent and integrated software solutions for tomorrow’s cities at this year’s ITS World Congress in Hamburg under the banner “Discover PSI’s Smart City Ecosystem”.

The city should be smart – networked, quiet, clean and congestion-free. A lot is riding on urban mobility and on the optimization of traffic and energy flows.

Multi-criteria, AI-based decision-making software can provide efficient support here, for example in bypassing traffic jams, busy roads or residential areas. The electrification and automation of public transport is also playing an increasingly important role in achieving climate protection goals and reducing CO2 emissions.

Predictive traffic control, smart power grids, integrated depot and charging management for e-vehicles or automated, energy-efficient rail

transport – to find out how intelligent software products can make cities more sustainable, cost-effective and livable, visit our booth (number B5002) in Hall 5. We look forward to seeing you there. 🌿

Tickets: info@psitranscom.de

PSI Transcom GmbH
Susanne Renner
Marketing Manager
srenner@psi.de
www.psitranscom.com

40 Years of PSI Transcom – Thank You for Your Trust!

In 2021, we look back on over four decades of software development for public transport. During this time, we have evolved into one of the leading specialists for innovative control technology solutions in public transport and regional rail services.

As early as the 1980s, while still under the umbrella of AEG, we were involved in the implementation of electronic interlockings and the magnetic train system for BVG Berlin. Our software for over 50 passenger information systems was delivered to Germany, Spain and Finland for Adtranz, now Alstom. We have been an integral part of PSI Software AG as a fully owned subsidiary since 2000.

We managed to expand our range of services and thus significantly strengthen our market position through the addition of Moveo Software GmbH to our team in 2018. The Profahr personnel dispatching system constitutes an ideal complement to the PSITraffic solution portfolio.

Nowadays, transport companies in the largest German cities rely on our solutions.

With over 40 years of experience, we have gained a deep understanding of your requirements. Therefore, our focus is on the continuous development of our software products. In collaboration with you, we want to promote the implementation of digitalization and support you in the

expansion of e-mobility. We look forward to continuing to support you as a reliable expert and partner in mastering your tasks in the future. ☺

PSI Transcom GmbH

Susanne Renner
Marketing Manager
srenner@psi.de
www.psitranscom.com



MOBILITY manager

Also online:
The MOBILITY manager
and further
magazines for
companies in the energy and
production sectors.



PSI-Blog

Here you can
find more
contributions
on mobility,
energy, AI, production and
logistics.



IMPRINT

Publisher

PSI Transcom GmbH
Dircksenstraße 42-44
10178 Berlin
Germany
Phone: +49 30 2801-1610
Fax: +49 30 2801-1032
info@psitranscom.de
www.psitranscom.com

Editorial and Layout

Susanne Renner

Printing

Druckhaus Sportflieger

DATA PROTECTION

Please note our privacy policy at
www.psi.de/en/privacy/.

SOURCES

Page 1: istock.com/dennisvdw
Page 2, 4, 5, 8, 9, 12, 13, 14, 23: PSI
Page 6, 7: DB AG/Sophie Fiebeler
Page 10, 11, 15 adobestock.com
Page 16, 17, 20: Moveo
Page 19: BLT Baselland
Page 21: Verkehrsbetriebe Zürich
Page 22: Umweltforum

PSI Transcom GmbH

Dircksenstraße 42-44

10178 Berlin

Germany

Phone: +49 30 2801-1610

Fax: +49 30 2801-1032

info@psitranscom.de

www.psitranscom.com